

THIS DRAWING IS THE PROPERTY OF PIERCE MANUFACTURING. IT IS CONFIDENTIAL AND ALL RIGHTS ARE RESERVED. IT SHALL NOT BE REPRODUCED, COPIED, LENT, OR USED FOR ANY PURPOSE OTHER THAN THAT FOR WHICH IT IS SPECIFICALLY FURNISHED.

BID # 000
 REP: Steve Williamson - Frontline Communications
 DEALER: Karl Schultz - Conrad Fire Equipment

PRELIMINARY USE ONLY
 THIS DRAWING IS FOR REPRESENTATION ONLY. DETAILED ENGINEERING DRAWINGS WILL BE CREATED FOR MANUFACTURING. CHANGES MAY BE REQUIRED TO ACCOMMODATE MANUFACTURING REQUIREMENTS AND CUSTOMER SPECIFICATIONS.

FRONTLINE COMMUNICATIONS
 An Oshkosh Corporation Business

DRAWN	JRP	DATE	03/28/25
SHEET	1 OF 6	NOT TO SCALE	

Kansas City FD (MO)
 Mobile Command Unit
 C-45 X-4 - Velocity

SIZE	B	DWG NO.	P2024-108	REV	A
------	---	---------	-----------	-----	---

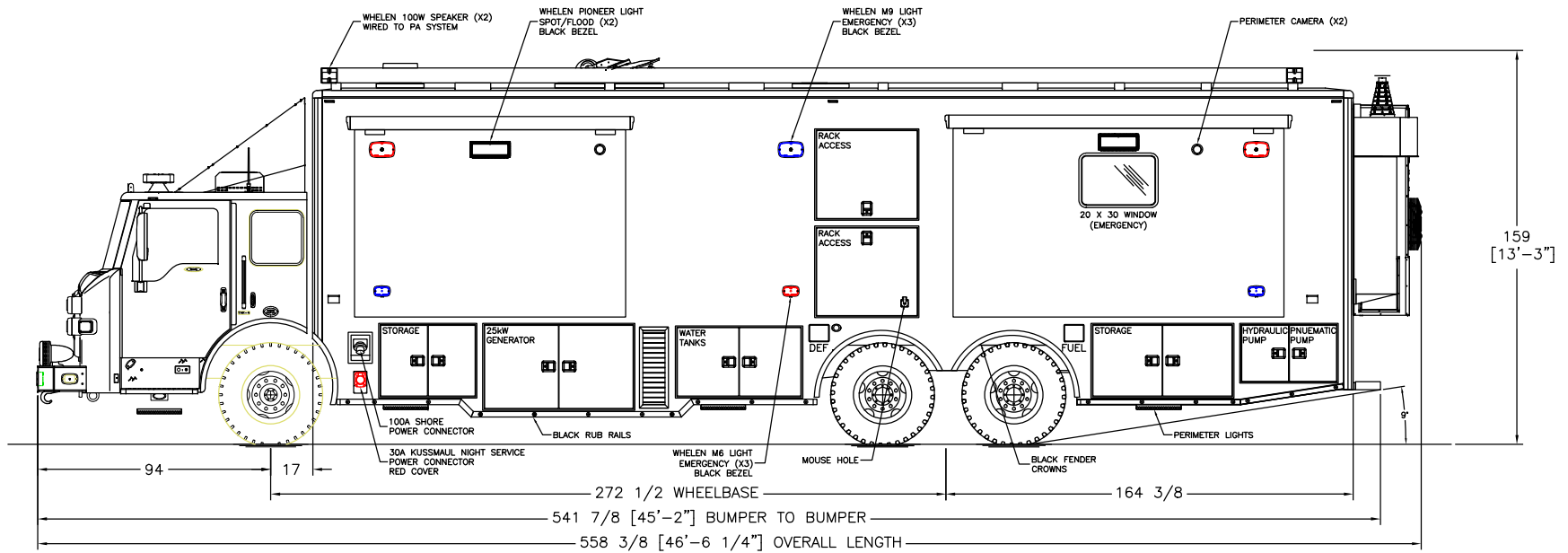

THIS DRAWING IS THE PROPERTY OF PIERCE MANUFACTURING. IT IS CONFIDENTIAL AND ALL RIGHTS ARE RESERVED. IT SHALL NOT BE REPRODUCED, COPIED, LENT, OR USED FOR ANY PURPOSE OTHER THAN THAT FOR WHICH IT IS SPECIFICALLY FURNISHED.

BID # 000
 REP: Steve Williamson - Frontline Communications
 DEALER: Karl Schultz - Conrad Fire Equipment

PRELIMINARY USE ONLY
 THIS DRAWING IS FOR REPRESENTATION ONLY. DETAILED ENGINEERING DRAWINGS WILL BE CREATED FOR MANUFACTURING. CHANGES MAY BE REQUIRED TO ACCOMMODATE MANUFACTURING REQUIREMENTS AND CUSTOMER SPECIFICATIONS.



DRAWN JRP
 SHEET 2 OF 6
 DATE 03/28/25
 NOT TO SCALE

Kansas City FD (MO)
 Mobile Command Unit
 C-45 X-4 - Velocity

SIZE B
 DWG NO. P2024-108
 REV A

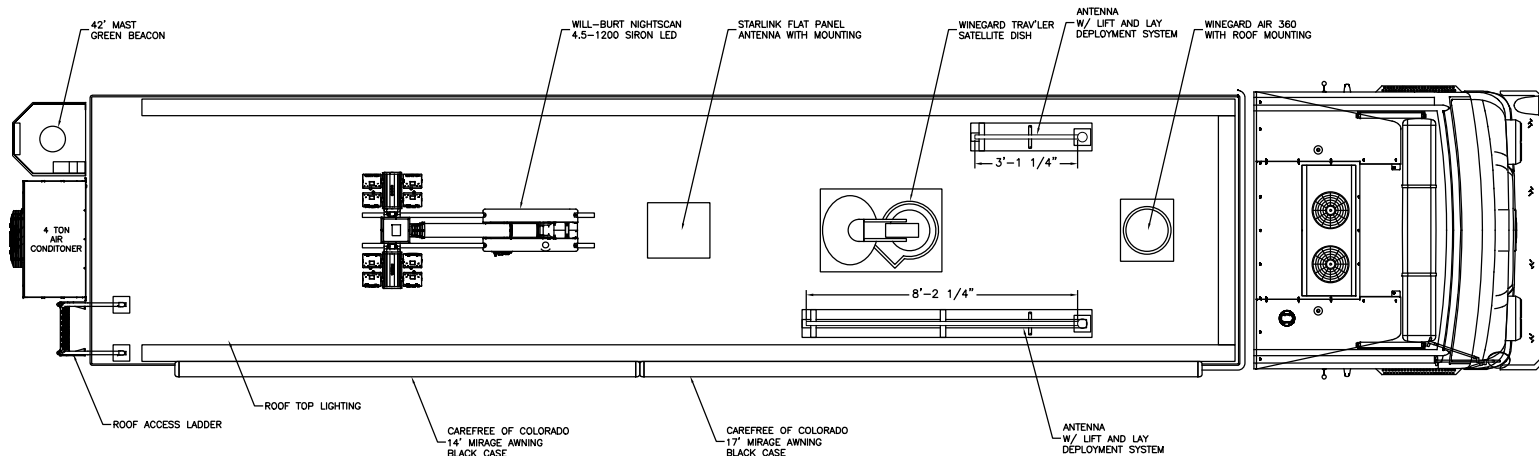

THIS DRAWING IS THE PROPERTY OF PIERCE MANUFACTURING. IT IS CONFIDENTIAL AND ALL RIGHTS ARE RESERVED. IT SHALL NOT BE REPRODUCED, COPIED, LENT, OR USED FOR ANY PURPOSE OTHER THAN THAT FOR WHICH IT IS SPECIFICALLY FURNISHED.

BID # 000
 REP: Steve Williamson - Frontline Communications
 DEALER: Karl Schultz - Conrad Fire Equipment

PRELIMINARY USE ONLY
 THIS DRAWING IS FOR REPRESENTATION ONLY. DETAILED ENGINEERING DRAWINGS WILL BE CREATED FOR MANUFACTURING. CHANGES MAY BE REQUIRED TO ACCOMMODATE MANUFACTURING REQUIREMENTS AND CUSTOMER SPECIFICATIONS.



DRAWN	JRP	DATE	03/28/25
SHEET	3 OF 6	NOT TO SCALE	

Kansas City FD (MO) Mobile Command Unit C-45 X-4 - Velocity	
SIZE	DWG NO.
B	P2024-108
REV	A

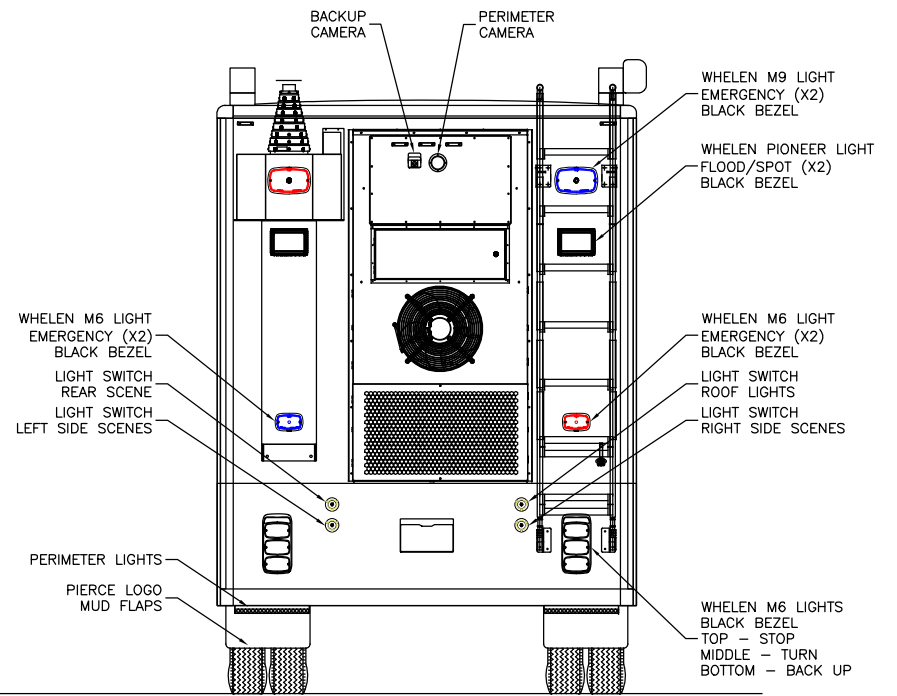
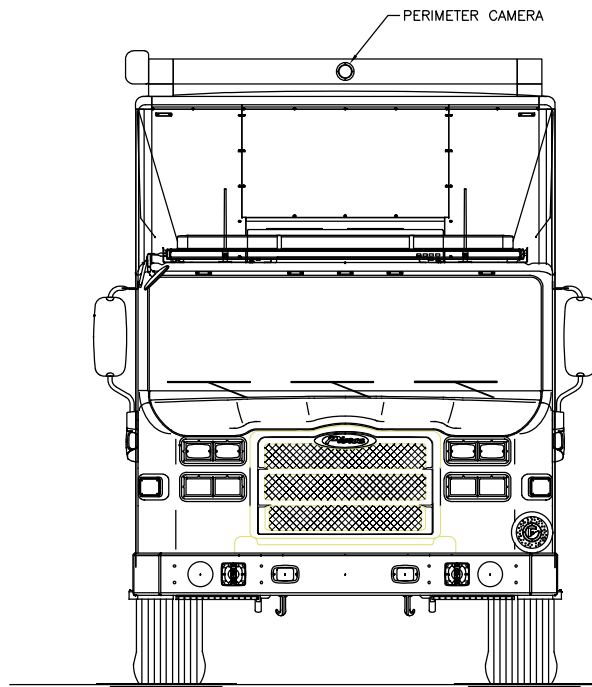

THIS DRAWING IS THE PROPERTY OF PIERCE MANUFACTURING. IT IS CONFIDENTIAL AND ALL RIGHTS ARE RESERVED. IT SHALL NOT BE REPRODUCED, COPIED, LENT, OR USED FOR ANY PURPOSE OTHER THAN THAT FOR WHICH IT IS SPECIFICALLY FURNISHED.

BID # 000
 REP: Steve Williamson - Frontline Communications
 DEALER: Karl Schultz - Conrad Fire Equipment

PRELIMINARY USE ONLY
 THIS DRAWING IS FOR REPRESENTATION ONLY. DETAILED ENGINEERING DRAWINGS WILL BE CREATED FOR MANUFACTURING. CHANGES MAY BE REQUIRED TO ACCOMMODATE MANUFACTURING REQUIREMENTS AND CUSTOMER SPECIFICATIONS.

FRONTLINE COMMUNICATIONS
 An Oshkosh Corporation Business

DRAWN	JRP	DATE	03/28/25
SHEET	4 OF 6	NOT TO SCALE	

Kansas City FD (MO)
 Mobile Command Unit
 C-45 X-4 - Velocity

SIZE	B	DWG NO.	P2024-108	REV	A
------	---	---------	-----------	-----	---

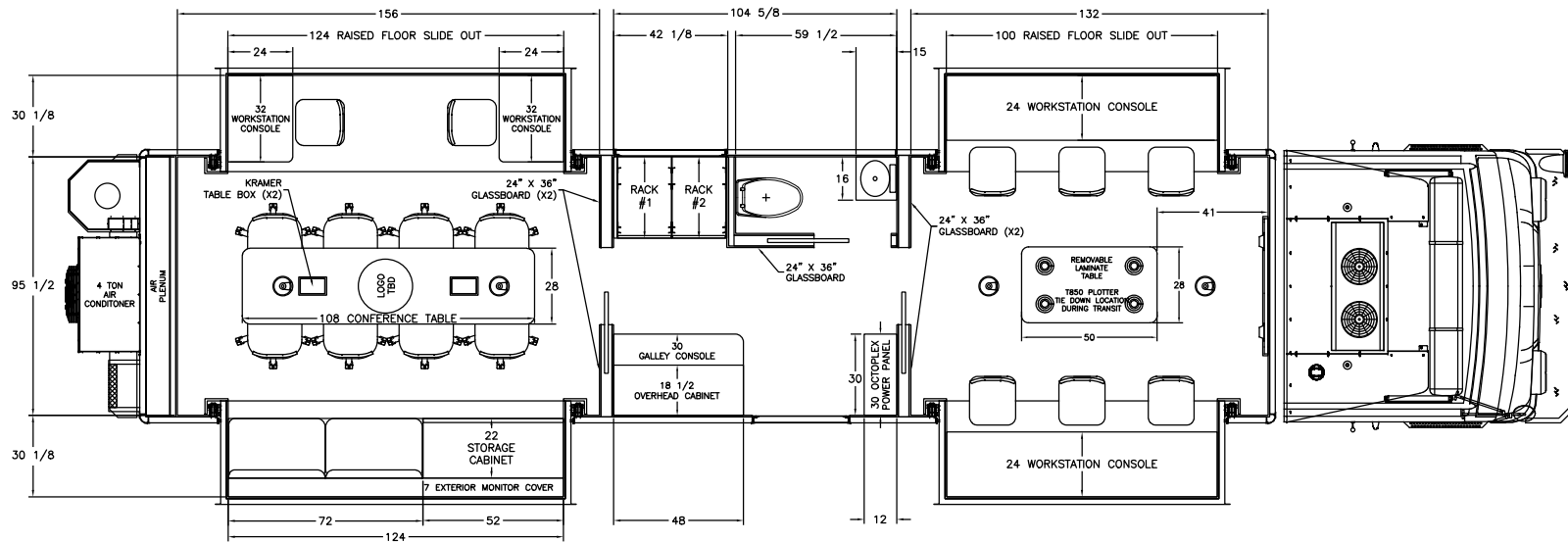

NOTES:

- 1) CONSOLES – SOLID SURFACE DOVE (GRAY)
- 2) REMOVABLE TABLE – GRAY MICA COVERED PLYWOOD
- 3) PLOTTER TIE DOWNS AT REMOVABLE TABLE LOCATION
- 4) CEILING LIGHTS DIMMABLE RED/WHITE
- 5) CEILING SPEAKERS IN CONFERENCE AND FRONT ROOM
- 6) RACKS INCLUDE REMOVALBE MESH DOORS
- 7) FLOORING BLACK LONSEAL

THIS DRAWING IS THE PROPERTY OF PIERCE MANUFACTURING. IT IS CONFIDENTIAL AND ALL RIGHTS ARE RESERVED. IT SHALL NOT BE REPRODUCED, COPIED, LENT, OR USED FOR ANY PURPOSE OTHER THAN THAT FOR WHICH IT IS SPECIFICALLY FURNISHED.

BID # 000
 REP: Steve Williamson - Frontline Communications
 DEALER: Karl Schultz - Conrad Fire Equipment

PRELIMINARY USE ONLY
 THIS DRAWING IS FOR REPRESENTATION ONLY. DETAILED ENGINEERING DRAWINGS WILL BE CREATED FOR MANUFACTURING. CHANGES MAY BE REQUIRED TO ACCOMMODATE MANUFACTURING REQUIREMENTS AND CUSTOMER SPECIFICATIONS.

FRONTLINE COMMUNICATIONS
 An Oshkosh Corporation Business

DRAWN	JRP	DATE	03/28/25
SHEET	5 OF 6	NOT TO SCALE	

Kansas City FD (MO)
 Mobile Command Unit
 C-45 X-4 - Velocity

SIZE	DWG NO.	REV
B	P2024-108	A

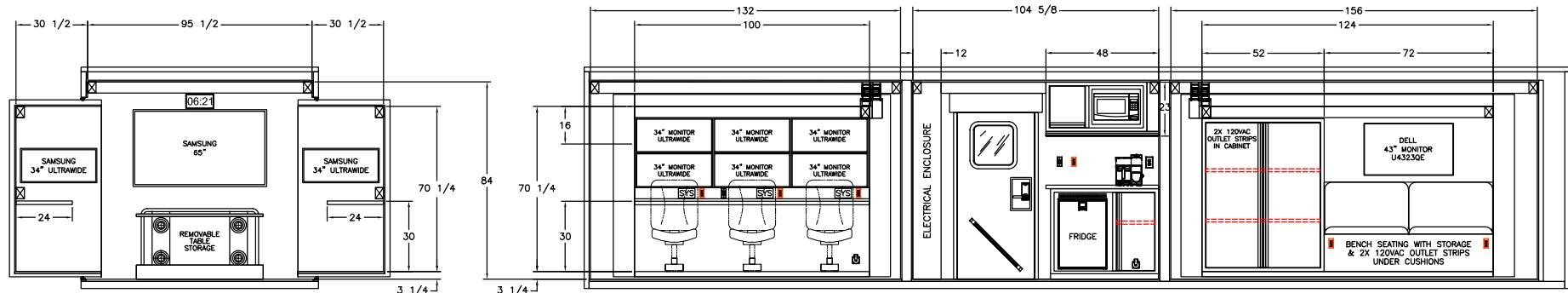

FRONT WALL INTERIOR LAYOUT

PASSENGER SIDE INTERIOR LAYOUT

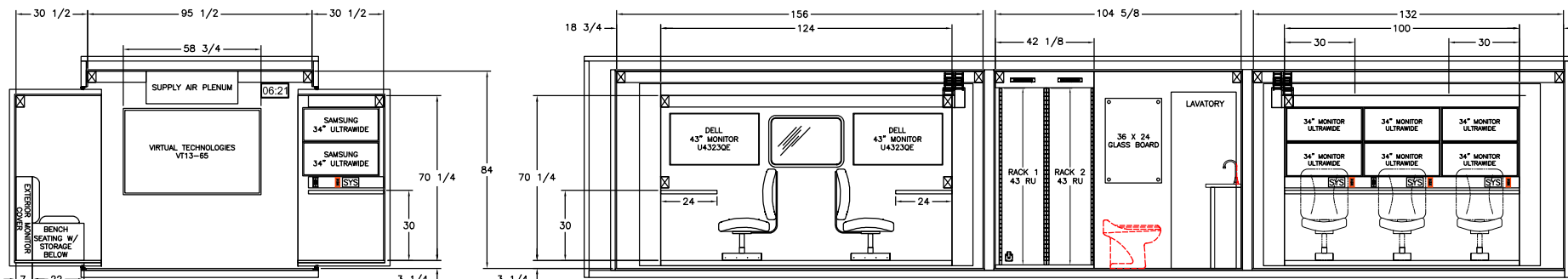

REAR WALL INTERIOR LAYOUT

DRIVER SIDE INTERIOR LAYOUT

THIS DRAWING IS THE PROPERTY OF PIERCE MANUFACTURING. IT IS CONFIDENTIAL AND ALL RIGHTS ARE RESERVED. IT SHALL NOT BE REPRODUCED, COPIED, LENT, OR USED FOR ANY PURPOSE OTHER THAN THAT FOR WHICH IT IS SPECIFICALLY FURNISHED.

BID # 000
 REP: Steve Williamson - Frontline Communications
 DEALER: Karl Schultz - Conrad Fire Equipment

PRELIMINARY USE ONLY
 THIS DRAWING IS FOR REPRESENTATION ONLY. DETAILED ENGINEERING DRAWINGS WILL BE CREATED FOR MANUFACTURING. CHANGES MAY BE REQUIRED TO ACCOMMODATE MANUFACTURING REQUIREMENTS AND CUSTOMER SPECIFICATIONS.



DRAWN JRP DATE 03/28/25
 SHEET 6 OF 6 NOT TO SCALE

Kansas City FD (MO)
 Mobile Command Unit
 C-45 X-4 - Velocity

SIZE B DWG NO. P2024-108 REV A